

## INSTALLATION: CFE PLUS HARNESS

### WHAT IS THE CFE PLUS

The CFE-Plus (Canbus Function Extender Plus edition) is an add-on CPU (Computer) for your Volvo. Since it acts as another CPU in your Volvo, the CFE Plus is capable of adding functions. (See the CFE Product page on our website for details on all possible functions).

The CFE Plus comes as an OBD dongle. (OBD is On Board Diagnostics; a connector available at the doorside of the steeringwheel, behind a hatch).

For Volvo's (S80, V70, XC70, S60, XC90) from Modelyears 01 up to 04, a direct connection to the OBD port is NOT possible and a specific harness is required.

This manual describes the installation procedure for the harness.

### KNOWLEDGE/TOOLS AND EXTRA'S REQUIRED

To be able to connect the harness to your Volvo, you'll need some tools.

\* Flat screwdriver \* Torx 25 screwdriver \* Size 10 wrench (alternatively : flat bottom pliers) \* Strip pliers \*2 self tapping screws or double-sided-tape to mount the connector

### FIRST STEPS

Remove ALL cd's from the CD player in the radio unit. Disconnect the battery ground (see your Volvo's user manual), leave key in position 2 ! (Confirm by switching lights in position 1 (middle), lights should be off, leave light switch in position 1!)

### THE HARNESS

The harness consists of a female OBD connector (which fits directly to the CFE Plus).  
On the other side there are 6 wires available.

### SUPPLIED HARNESS

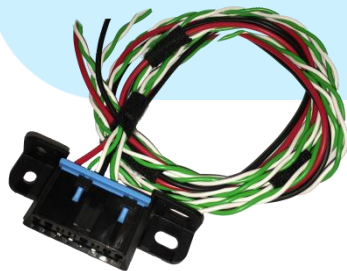

#### Wires:

1 long (1200mm length) set of twisted green/white wires -> Highspeed bus

1 short (800mm length) set of twisted green/white wires -> Lowspeed bus

1 black (800mm length) wire -> ground

1 red (800mm length) wire -> 12V+ battery

|                   |               |            |      |            |
|-------------------|---------------|------------|------|------------|
| Instruction# 1697 | Version# 1.06 | Part# ntbp | EAN# | Author: KW |
|-------------------|---------------|------------|------|------------|

## PINOUT

Pinout of the harness;

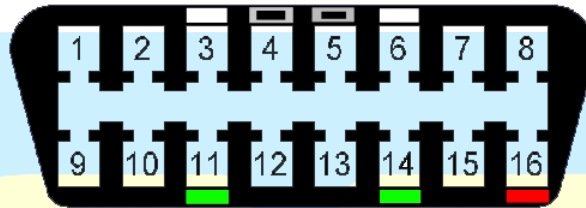

| Pin | Color | Type   | Function                  | Connect to         | Remark                     |
|-----|-------|--------|---------------------------|--------------------|----------------------------|
| 16  | RED   | 12V+   | 12V+ Battery for CFE Plus | +30 (12V+ Battery) | Do not use ignition power! |
| 4/5 | BLACK | GND    | GND for CFE Plus          | GND                |                            |
| 3   | WHITE | Canbus | Can LS H                  | Canbus LS          | Twisted with 11            |
| 11  | Green | Canbus | Can LS L                  | Canbus LS          | Twisted with 3             |
| 6   | WHITE | Canbus | Can HS H                  | Canbus HS          | Twisted with 14            |
| 14  | Green | Canbus | Can HS L                  | Canbus HS          | Twisted with 6             |

## INSTALLATION PROCEDURE

The CFE Plus female connector is suggested to be mounted inside the glove compartment (for V70/XC70/S70/S80) or behind the removable panel next to the tunnel (XC90).

Put connector as planned (do not mount it with screws or double sided tape yet) on the place suggested (or any other place you like, taking the wire-lengths in consideration).

### Step 1 : remove the radio unit.

For S60/V70/XC70/S80:

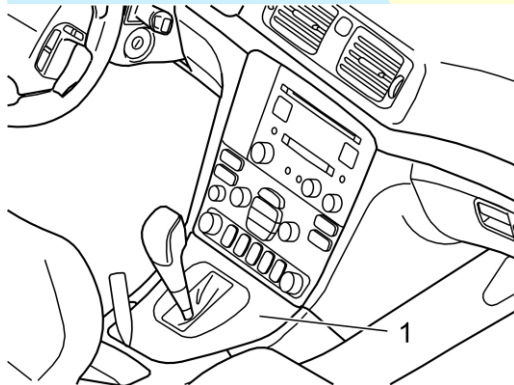

1 -> use fishbone tool to remove the pen-holder and to lift the gear-selector-cover.

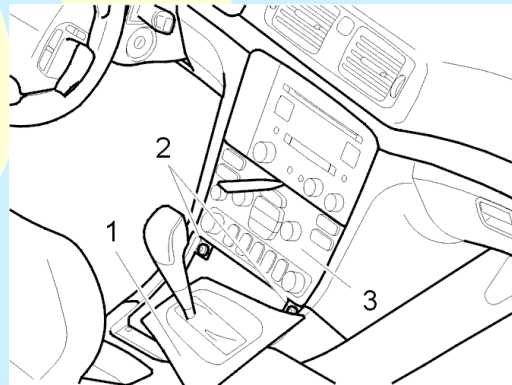

2-> remove the 2 torx 2 screws  
3-> insert fishbone to lower the climate control panel.

|                   |               |            |      |            |
|-------------------|---------------|------------|------|------------|
| Instruction# 1697 | Version# 1.06 | Part# ntbp | EAN# | Author: KW |
|-------------------|---------------|------------|------|------------|

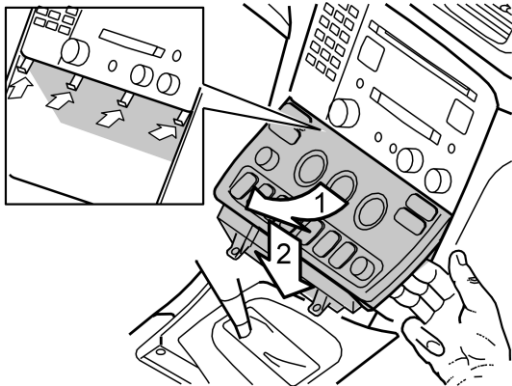

1- Lower the climate control panel and lift it

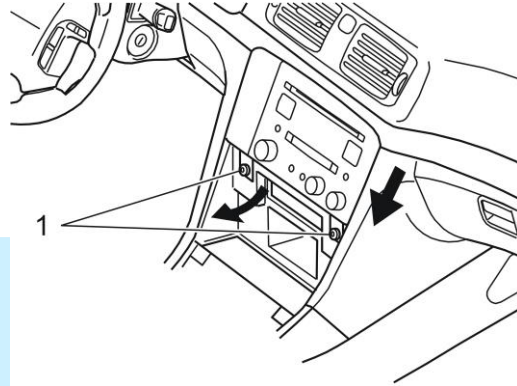

1- Remove the 2 torx 20 screws, tilt forward / lower the radio unit to pull it out.

**For XC90:**

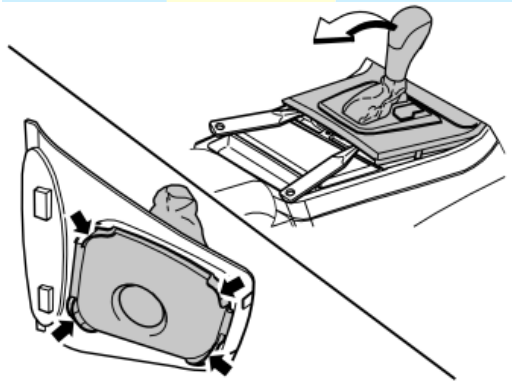

**Step 2; remove the protective cover  
(For all models)**

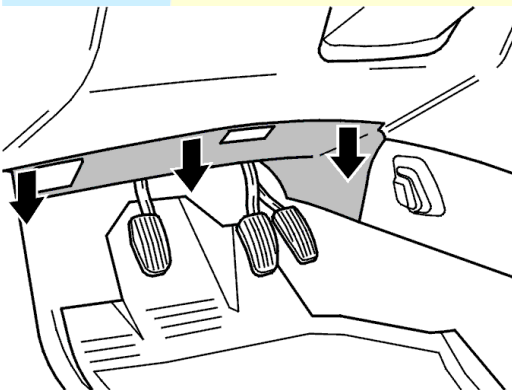
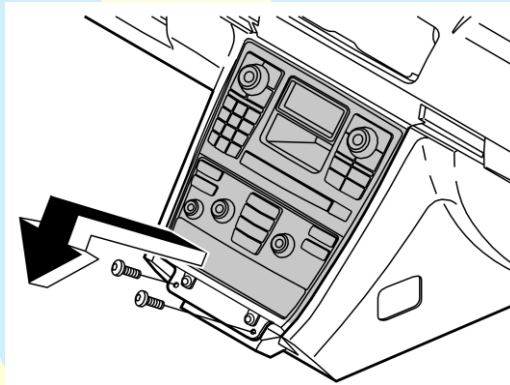

|                   |               |            |      |            |
|-------------------|---------------|------------|------|------------|
| Instruction# 1697 | Version# 1.06 | Part# ntbp | EAN# | Author: KW |
|-------------------|---------------|------------|------|------------|

**Step 3; remove the "CEM" (Central Electronics Module / relay box)**  
*(For all models)*

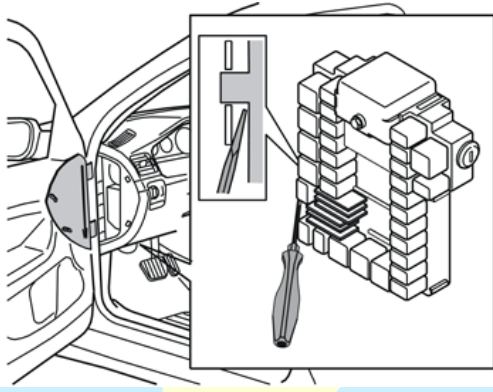

1-> Remove side cover (in case you can't reach the bracket from below, try to reach from here, removal of the fusebox might be required!)

2-> Insert a screwdriver up between the bracket and the relay box. Turn the screwdriver so that the bracket expands and, at the same time, pull the relay box from the bracket towards the underside of the dashboard. Lift away the relay box from the bracket and pull it downward under the dashboard.

**Step 4; remove harness from CEM**  
*(For all models)*

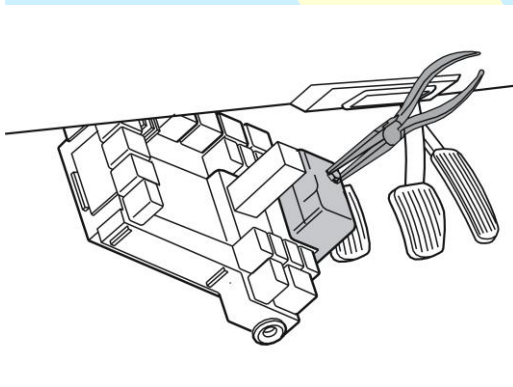

1->Remove the bolt from the cover.  
(This step is a requirement, the cover (next step) can be removed without removing this bolt in most cases!)

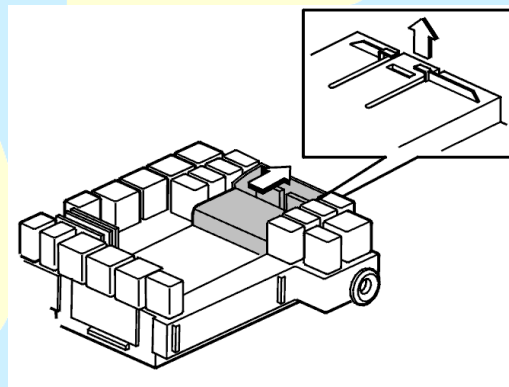

2-> remove the cover. There's NO need to remove the connectors from the CEM!

|                   |               |            |      |            |
|-------------------|---------------|------------|------|------------|
| Instruction# 1697 | Version# 1.06 | Part# ntbp | EAN# | Author: KW |
|-------------------|---------------|------------|------|------------|

**Step 5; guide the wires**

From glove compartment (or side of tunnel -XC90-) towards the CEM location for the LONGER (marked "HS-Can") cable.

The SHORTER (Marked "LS-Can" and power -Red and black-) wires have to be connected behind the Radio unit, so leave them there for now.

**Step 6; identify the wires required (highspeed canbus) and connections (HS-Can)**

(For all models)

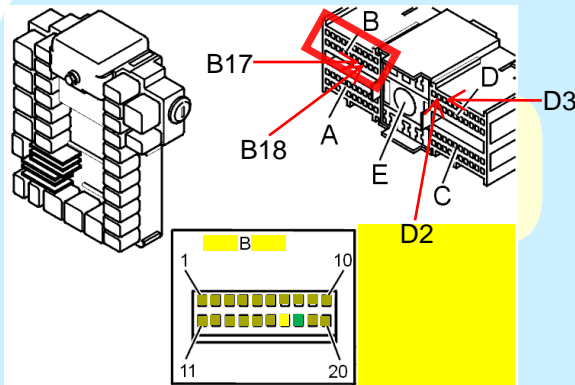

For HS-Can connection.

**Point of view :** Connector side (which goes into the CEM)

From the main connector going into the CEM, we'll use inner connector B (marked with **red square**) to connect to the **Highspeed canbus** network.

The **WHITE** HS-Can connection wire -> connects to the wire coming out of **Pin B17** (should also be white!)

The **GREEN** HS-Can connection wire -> connects to the wire coming out of **Pin B18** (should also be green!)

In case you want to connect the **Lowspeed canbus** here as well **instead** of to the back of the radio unit:

The **WHITE** LS-Can connection wire -> connects to the wire coming out of **Pin D3** (should also be white!)

The **GREEN** LS-Can connection wire -> connects to the wire coming out of **Pin D2** (should also be green!)

**Step 7; identify the wires required (lowspeed canbus) and the connections (LS-Can)**

(For S60/V70/Xc70/S80)

At the back of the HU, find the GREEN 12pin connector.

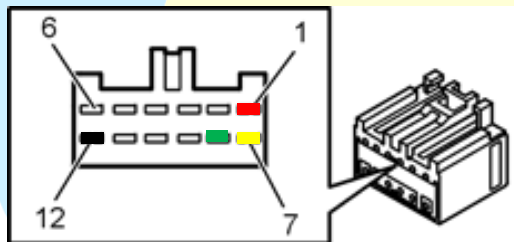

**Point of view :** Connector side (which goes into the HU)

The **RED** wire from the CFE Plus harness -> **Pin 1** (Pin 1 should contain a **Red** wire!)

The **BLACK** wire from the CFE Plus harness -> **Pin 12** (Pin 12 should contain a **Brown** wire!)

The **white** wire from the CFE Plus harness -> **Pin 7** (should also be **white**!)

The **green** wire from the CFE Plus harness -> **Pin 8** (should also be **green**!)

\*\*\* IF you see different wire colors in the green connector than set out above, please make sure you work with the ORIGINAL Volvo connector. In some cases (aftermarket Bluetooth systems etc) there might be an in-between connector connected to the HU, the original cable is then to be found nearby (behind the HU as well). Colors of aftermarket harnesses might differ!!

|                   |               |            |      |            |
|-------------------|---------------|------------|------|------------|
| Instruction# 1697 | Version# 1.06 | Part# ntbp | EAN# | Author: KW |
|-------------------|---------------|------------|------|------------|

(For XC90)

At the back of the ICM (display) find the GREEN 10 pin connector.

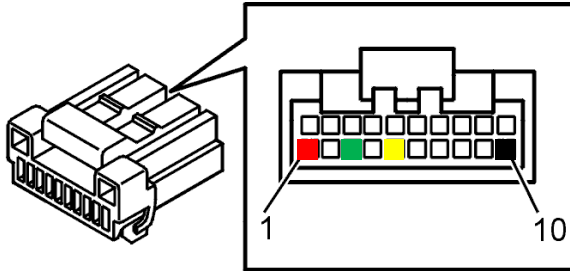

Point of view : Connector side (which goes into the )

- The **RED** wire from the CFE Plus harness -> **Pin 1**  
(Pin 1 should contain a **Purple** wire!)
- The **BLACK** wire from the CFE Plus harness -> **Pin 10**  
(Pin 10 should contain a **Brown** wire!)
- The **white** wire from the CFE Plus harness -> **Pin 5**  
(should also be **white!**)
- The **green** wire from the CFE Plus harness -> **Pin 3**  
(should also be **green!**)

**Step 7; Test the connections.**  
(For all models)

- 1- *Make sure you have reconnected (temporarily if required) all connections.*
- 2- *Make sure key is still in ignition position 2.*
- 3- *Make sure light switch is still in position 1 (middle position)*
- 4- *Reconnect ground cable to the battery*
- 5- *Now check if your car operates like normal, start car, let it run a minute and switch it back off*
- 6- *Put key in ignition position 2*
- 7- *Connect the CFE Plus (make sure its configured with the right VIN!) to the OBD port you just created.*
- 8- *Now you should see the blue high-beam light flash 3 times, be lit for a second or 10 and flash 3 times again.*

*If you see the blue high-beam light flash/being lit, you can start re-installing all removed parts, installation was successful!*

*If you did not see the high-beam light flash/being lit, please remove the CFE Plus and reconnect. Pay close attention to the dashboard to see if the blue high-beam light is lit/flashes.*

*In case it does not flash, please check the configuration of the CFE first (make sure CFE Plus's general settings is "MODE 1" or "MODE 2" and at least 1 function is "enabled" and has the selected MODE activated as well, and try again after any change has been made to the config.*

*If configuration seems okay, please check all connections carefully.*

*Please read our [Knowledge base for additional support](#) or enter a [ticket in our support system](#) for personal support!*

**Howto; connect the CFE Plus harness's wires to an existing wire in the car.**

Strip (1) the wire to be connected to at a place where you can reach it good enough to make an 'eye' (2) with a sharp object and to put the CFE Plus cable (3) trough, twist it and cover it with isolation tape.

|                   |               |            |      |            |
|-------------------|---------------|------------|------|------------|
| Instruction# 1697 | Version# 1.06 | Part# ntbp | EAN# | Author: KW |
|-------------------|---------------|------------|------|------------|

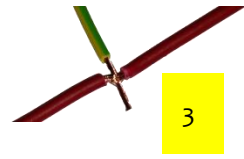
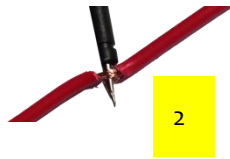

|                   |               |            |      |            |
|-------------------|---------------|------------|------|------------|
| Instruction# 1697 | Version# 1.06 | Part# ntbp | EAN# | Author: KW |
|-------------------|---------------|------------|------|------------|